

## Fire Risk Assessment

### HSF 91

This Fire Risk Assessment was undertaken in order to comply with the Regulatory Reform (Fire Safety) Order 2005 (the “Fire Safety Order”).

The purpose of the report is to provide an assessment of the risk to life from fire, and where appropriate, to make recommendations to ensure compliance with fire safety legislation.

The report does not necessarily address the risk to property or business continuity from fire.

The survey was conducted as a “non-invasive” survey and only those areas of the building structure that were readily accessible were inspected.

The survey did not access inaccessible areas such as ducts, or all basements, lofts or ceiling voids.

Responsible person	<i>Vicki Bradley (HT/Premises manager)</i>
Address of premises	<i>All Saints CE(VC) First School Church Lane Standon Staffordshire ST21 6RN</i>
HSW Service Assessor	<i>John Burdett (Fire Risk Assessment Training from Kelly, May 2021)</i>
Date fire risk assessment completed	<i>February 2023</i>
Date of previous fire risk assessment	<i>June 2021 (following training)</i>
Suggested date for review	<i>February 2024</i>

Health Safety and Wellbeing Service

[shss@staffordshire.gov.uk](mailto:shss@staffordshire.gov.uk)

01785 355777

## General Information

### 1. The Premises

1.1	Use of premises	<i>Provision of education for children aged 3 to 9. Provision of before and after school care for children aged 3 to 9. No lettings.</i>
1.2	Number of floors	1
	Approximate floor area (m <sup>2</sup> )	389
	Number of basements	0
	Number of stairs	0

1.3 Brief details of construction and layout of each building

*Brick, glass and UPVC window frames.  
Some asbestos on interior floors (tiling of storage cupboards) see Asbestos Register for more details  
Flat roof  
Wooden hall floor  
N.B. Plan below to be updated when received from SCC.*

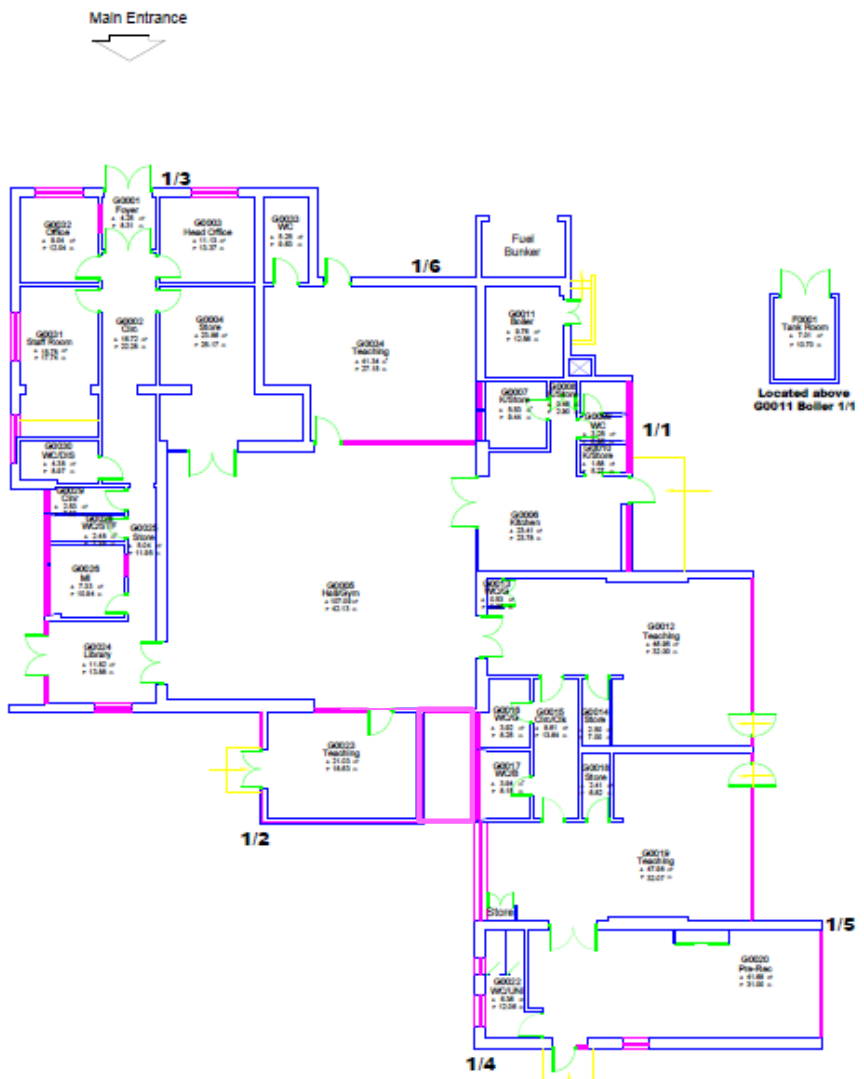

<b>2. The Occupants</b>				
2.1	Approximate total number of people present in the building at any one time	<i>80 Up to 200 – for events e.g. school performance Up to 30 – for Parents Evenings</i>		
2.2	Approximate maximum number of employees at any one time	Day	Night	
		<i>14</i>	<i>0</i>	
2.3	Approximate maximum number of other occupants at any one time	Day	Night	
		<i>66</i>	<i>0</i>	
2.4	Hours of occupation	<i>06:30 to 17:30 weekdays only (excluding holiday periods when building is empty) 17:30 to 20:00 school performances &amp; Parent evenings</i>		
<b>3. Occupants especially at risk from fire</b>				
3.1	Sleeping occupants	<i>0</i>		
3.2	Disabled occupants	<i>0 (at present day to day)</i>		
3.3	Visual/hearing impairment	<i>0 (at present day to day)</i>		
3.4	Young persons	<i>72</i>		
3.5	Occupants in remote areas and lone workers	<i>No remote areas Lone worker from 06:30 to 07:00</i>		
3.6	Non-English speakers	<i>0 (at present day to day)</i>		
3.7	Others (e.g. visitors/contractors)	<i>Visitors – 1 to 2 at any one time Contractors – varies according to activity on site. Hazard Exchange Forms completed prior to all works.</i>		
<b>4. Record of recent fires</b>				
<i>None Controlled fire lit for Forest School approximately 3 times per week. Fire Service notified by Forest School leader prior to each occasion.</i>				
<b>5. Electrical sources of ignition</b>				
5.1	Is the fixed electrical installation periodically inspected and tested?	<b>Yes</b> – 5 year cycle	No	Date 29.06.2016 29.06.2021
5.2	Is portable appliance testing (PAT) carried out?	<b>Yes</b> – annually by Calbarrie	No	Date 06.07.2022

5.3	Have the recommended actions raised in the testing in 5.1 and 5.2 above been completed?	Yes	No	
5.4	Is there a policy in place regarding the use of personal electrical appliances?	Yes –	No	
5.5	Is there excessive use of extension leads and plug adapters?		No	
5.6	Is the use of charging devices controlled?	Yes	No	
5.7	Further comments or hazards observed	<p>Staff are asked not to bring in electrical items from home unless agreed with HT. HT only agrees to items that are new or have been PAT tested in previous 12 months.</p> <p>Staff are advised against this wherever possible. However, extension leads are necessary in some classrooms to run interactive whiteboards etc. Staff are encouraged to turn off sockets daily and remove all plugs over holiday periods.</p>		
<b>6. Smoking</b>				
6.1	Is smoking prohibited on the premises?	Yes	No	
6.2	Are there suitable arrangements for those wishing to smoke?	Yes	No	n/a
6.3	Is there evidence that the smoking arrangements are not being followed?	Yes	No	n/a
6.4	Further comments or hazards observed at the time of inspection	<p>Smoking/vaping is not permitted anywhere on site Contractors are advised not to smoke on site or in the immediate vicinity of the school grounds</p>		
<b>7. Arson</b>				
7.1	Have you considered the risk of arson as part of your site security measures?	Yes	No	
7.2	Do you manage the external premises to ensure that risk of arson is minimised	Yes	No	
7.3	Further comments and hazards observed from 7.1 and 7.2. If you have also answered “No” to any question above provide further detail of the action required to resolve the issue and add this to the action plan.	<p>Fortunate not to experience any anti-social behaviour on or around school site in previous 7 years. Caretaker regularly inspects grounds to ensure risks are eliminated where possible.</p> <p>Large refuse bins at rear of school are a potential risk and have been located as far from the building as possible whilst ensuring the safety of the children at playtimes.</p>		
<b>8. Portable heaters and heating installations</b>				
8.1	Do you use portable heaters in your premises?	Yes	No	

8.2	Do you take measures to minimise the risk from these such as the ignition of combustible materials?	Yes	No	n/a
8.3	Are your heating systems subject to regular maintenance?	Yes	No	
8.4	Please add further comments or observations regarding questions 8.1, 8.2 and 8.3 If you have answered "No" to any questions above please provide further detail of the action required to resolve the issue and add this to the action plan.	Boilers are subject to 6 monthly services Caretaker regularly carries out visual checks on oil tank		
<b>9. Cooking/Catering</b>				
9.1	Do you have cooking facilities on site?	Yes	No	
9.2	Do you have an external catering supplier/contractor?	Yes	No	
9.3	Have they carried out a Fire Risk Assessment?	Yes	No	n/a
9.4	If "Yes" do you have a copy of the fire risk assessment for their area?	Yes	No	n/a
9.5	If you do not have an external caterer do you have control measures in place to reduce the risk of fire during cooking?	Yes	No	n/a
9.6	Are service contracts in place for fire control measures and appliances such as gas shut-off valves/ automatic shut off devices and ventilation/suppression systems?	Yes	No	
9.7	Further comments and observations from questions 9.1-9.6 and if you have answered "No" to any question above please provide further details of the action required to resolve the issue and add this to the action plan.	Copy of City Catering Fire risk Assessment held by HT. Updated annually. All appropriate fire management measures are available in the kitchen. All equipment is inspected on an annual basis. School does not have gas. Automatic shut-off valves are fitted to relevant equipment.		
<b>10. Lightning</b>				
10.1	Do the premises have a lightning protection system?	Yes	No	
10.2	Does this have a servicing contract?	Yes	No	n/a

10.3	Further comments or if you have answered “No” to any question above please provide further detail of the action required to resolve the issue and add this to the action plan	<i>VB to consult with Entrust property management regarding Lightning protection system.</i>		
<b>11. Housekeeping</b>				
11.1	Is the standard of housekeeping adequate?	Yes	No	
11.2	Do combustible materials appear to be separated from ignition sources?	Yes	No	
11.3	Is unnecessary accumulation or inappropriate storage of combustible materials or waste avoided?	Yes	No	
11.4	Further comments and observations or if you have answered “No” to the question above please provide further detail of the action required to resolve the issue and add this to the action plan	<p>Combustible materials are kept, wherever possible in a locked shed sited away from the main building.</p> <p>Evacuation routes are kept clear and monitored by Premises Manager</p> <p>All fire doors are kept free from obstruction</p> <p>Where external doors lead to a locked area, they are not labelled as fire doors. However, all staff on site carry a key to unlock the gates should this be necessary.</p> <p>External doors that need to be kept locked for children’s safeguarding are fitted with thumb turn locks so that they can be quickly opened by adults in the event of fire.</p>		
<b>12. Shared Workplaces</b>				
12.1	Do you operate within a shared workplace	Yes	No	
12.2	If “yes,” have you made appropriate arrangements to share information about fire risks and communicated your fire safety arrangements?	Yes	No	n/a
12.3	Add further comments and observations from 12.1 and 12.2 and add any actions to the action plan			
<b>13. Fire hazards introduced by outside contractors and building works</b>				
13.1	Do you have arrangements in place for managing outside contractors on your premises?	Yes	No	
13.2	Are suitable precautions taken by in-house maintenance personnel who carry out works?	Yes	No	
13.3	If you have answered “No” please provide further details of the action	Hazard Exchange Forms are completed on site in a face-to-face meeting prior to any contractors attending site. Clear rules and expectations are given. This is re-visited		

	required to resolve the issue and add this to the action plan	periodically whilst contractors are on site and adjustments made if necessary.		
<b>14. Dangerous substances</b>				
14.1	Are the general fire precautions adequate to address the hazards associated with dangerous substances used or stored within the premises?	Yes	No	n/a
14.2	If you have answered "No" please provide further detail of the action required to resolve the issue and add this to the action plan			
<b>15 Other significant fire hazards that warrant consideration including process hazards that impact on general fire precautions</b>				
15.1	List the hazards	Oil fired heating system – tested regularly. Tank inspected regularly. Controlled fires lit during Forest School. Appropriate Risk Assessments in place		
15.2	Do you have control measures in place to manage the fire risks associated with these hazards?	Yes	No	n/a
15.3	If you have answered "No," please provide further detail of the action required to resolve the issue and add this to the action plan			
15.4	Comments and deficiencies observed			

<b>Fire protection measures</b>				
<b>16. Means of escape from fire</b>				
16.1	Is the provision of fire exits adequate?	Yes	No	
16.2	Exits are easily and immediately openable where necessary?	Yes	No	
16.3	Do fire exits open in direction of escape where necessary?	Yes	No	
16.4	Are the distances of travel to fire exits and protected routes reasonable and unobstructed?	Yes	No	

16.5	Please provide further comments on observations from 16.1-16.5 and if you have answered “No,” please provide further details of the actions required to resolve the issue and add this to the action plan	Termly fire drills consistently show that all children and adults can be evacuated from the building within approximately 1 minute of the alarm sounding. When school performances/fairs are held, records are kept to ascertain the approximate number of people in the building. Demonstrations of fire exits are given at the start of each event. Parents are asked to inform school if any of the ticket holders are disabled.		
<b>17. Evacuation of vulnerable people</b>				
17.1	Do you have adequate arrangements in place to evacuate vulnerable or disabled occupants?	Yes	No	
17.2	Is there adequate provision of equipment in place to facilitate evacuation of vulnerable or disabled people?	Yes	No	
17.3	Are the arrangements for evacuating vulnerable or disabled people (including PEEPs) tested for effectiveness as part of Fire Drills?	Yes	No	
17.4	Please provide further comments on your procedures from 17.1-17.3 and if you have answered “No,” please provide further details of the actions required to resolve the issue and add this to the action plan			
<b>18. Measures to limit fire spread and development.</b>				
18.1	Are you aware of the fire compartmentation arrangements in your premises?	Yes	No	
18.2	Are there any holes/damage to walls or breach of any compartmentation to your knowledge?	Yes	No	
18.3	Are fire resisting doors maintained in sound condition and self-closing where necessary?	Yes	No	
18.4	Are fire dampers present in the building and is a maintenance regime in place?	Yes	No	n/a
18.5	Please provide further comments on 18.1-18.4 and if you have answered “No,” please provide further details of the actions required to resolve the issue and add this to the action plan			
<b>19. Emergency escape lighting</b>				
19.1	Has a reasonable standard of emergency escape lighting system been provided?	Yes	No	
19.2	Is the lighting tested and maintained?	Yes	No	



19.3	If you have answered “No,” to any of the above please provide further detail of the action required to resolve the issue and add this to the action plan		
<b>20. Fire safety signs and notices</b>			
20.1	Are adequate fire safety signs and notices in place?	Yes	No
20.2	If “No” please provide details of the action required to resolve this include this in your action plan	All fire doors have fire exit signs, illuminated in the majority of cases. Each room has fire safety notices displayed with instructions and directional prompts for exiting the building from their given positions. Fire evacuation point is as far from the building as possible.	
<b>21. Fire Alarms</b>			
21.1	Is a reasonable fire detection and fire alarm system provided?	Yes	No
21.2	Is your system adequate and does it operate effectively?	Yes	No
21.3	Is a zone plan displayed?	Yes	No
21.4	Does the alarm signal transmit to an alarm receiving centre?	Yes	No
21.5	If Yes, are your key holder’s contact details regularly reviewed and updated with the alarm receiving centre?	Yes	No      n/a
21.6	Alarm testing and maintenance system in place and recorded?	Yes	No
21.6	Please provide further comments on 21.1-21.5 and if you have answered “No” please provide further details of the actions required to resolve the issue and add this to the action plan	A new fire alarm system was installed in October 2019. This is a fully monitored system which alerts both key holders and the fire service if the alarm is triggered. Staff on site are aware that the fire service must also be called in the event of fire. All key holder’s details are kept up to date. All key holders live within 5 minutes of the building. Alarm is tested every Monday morning during term time. Records are kept in the school entrance hall and past records in the HT’s office. Faults are noted on the records and signed and dated when fixed.	
<b>22. Manual fire extinguishing appliances</b>			
22.1	Is there suitable provision of portable fire extinguishers of the right type in the correct location?	Yes	No
22.2	Are they tested and maintained?	Yes	No
22.3	Are they accessible and not in locations where they can become hidden or blocked?	Yes	No

22.4	If you have answered “No” to any of the above, please provide further details of the action required to resolve the issue and add this to the action plan			
<b>23. Automatic fire extinguishing systems</b>				
23.1	Are there any automatic fire extinguishing systems in place?	Yes	No	
23.2	If “yes” are they tested and maintained?	Yes	No	n/a
23.3	Comments			

<b>Management of fire safety</b>				
<b>24. Procedures and arrangements</b>				
24.1	Fire safety is managed by:	Vicki Bradley		
24.2	Has anyone else working in the premises been given any fire safety responsibilities and are these clearly identified and understood?	Yes	No	
24.3	Is there a suitable record of the fire safety arrangements?	Yes	No	
24.4	Do you have in place routine in-house inspections of fire precautions and are these recorded in the manual?	Yes	No	
24.5	Are adequate fire procedures in place?	Yes	No	
24.6	If you have answered “No” to any of the above, please provide further details of the action required to resolve the issue and add this to the action plan	Members of staff on site have specific roles if the fire alarm sounds. Caretaker has responsibility for keeping the outside area tidy and free from risk.		
<b>25. Training and drills</b>				
25.1	Are all staff given adequate fire safety instruction and training?	Yes	No	
25.2	Are they given additional training to cover any specific roles and responsibilities?	Yes	No	
25.3	Are fire drills carried out at appropriate intervals?	Yes	No	
25.4	Provide further information on the training you provide and if you have answered “No,” to any of the above please provide further detail of the action required to resolve the issue and add this to the action plan	Annual refresher of roles and responsibilities given to staff. Fire drills occur termly and are recorded.		

26. Testing and maintenance			
26.1	Maintenance and testing of other fire precaution systems?	Yes	No
26.2	Are systems in place for reporting and managing safety measures that have fallen below standard or are faulty? e.g. a fault log	Yes	No
26.3	Are records kept for all the fire checks and tests identified above?	Yes	No
26.4	Is a system in place for people to report concerns with fire safety or fire safety system problems?	Yes	No
26.5	If you have answered "No," to the above please provide further detail of the action required to resolve the issue and add this to the action plan		

## Fire risk assessment – Risk Rating

A fire risk assessment considers the **likelihood** of fire in a premise (with fire prevention measures currently in place) in conjunction with the **potential consequences** in the event of a fire (death being the most extreme).

		Potential severity of harm					
		Slight Harm 1	Moderate Harm 2	Extreme Harm 3			
Likelihood of fire occurring	Highly unlikely 1	Trivial 1	Low 2	Medium 3			
	Unlikely 2	Low 2	Medium 4	High 6			
	Likely 3	Medium 3	High 6	High 9			
Risk Rating	Action Priority						
High (6-9)	Immediate action required. Considerable resources might have to be allocated to reduce the risk. If the premises are unoccupied, it should not be occupied until the risk has been reduced. If the premises are occupied, urgent action should be taken.						
Medium (3-4)	Actions to control the risk must now be considered and steps to manage the risk until control measures can be provided must implemented. It is essential that efforts are made to reduce the risk. Risk reduction measures, which should take cost into account, should be implemented within a defined time period. Where moderate risk is associated with consequences that constitute extreme harm, further assessment might be required to establish more precisely the likelihood of harm as a basis for determining the priority for improved control measures						
Low (2)	Implement reasonable control measures and monitor. No major additional fire precautions required. However, there might be a need for reasonably practicable improvements that involve minor or limited cost						
Trivial (1)	No action required unless level of harm or likelihood changes.						
<b>Based on the findings in this assessment the fire risk assessment for this building is:</b>							
High		Medium		Low	X	Trivial	

An action plan has been provided separately to The Responsible Person for this Fire Risk Assessment.